

DFKWF-PB Ball Joint (Female Screw 2 - Hole) - Round Pipe Mounting

Pipe

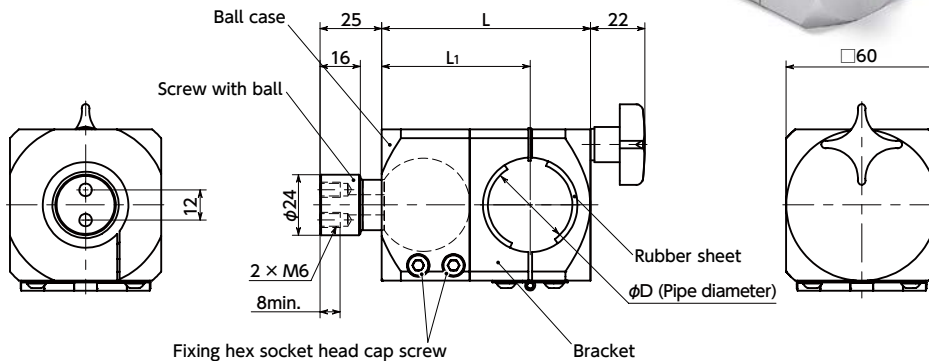

Material/Finish



	DFKWF-PB
Ball Case	A6063 Anodized
Screw with ball	S45C Trivalent Chromate Treatment
Fixing Hex Socket Head Cap Screw (M5×16mm)	SCM435 Ferrosferic Oxide Film
Bracket	A6063 Anodized
Rubber sheet	NR (Natural Rubber)

- A positioning component utilizing a ball screw. Mount the workpiece to the screw at the ball tip for use.
- The screw with ball can be tilted by $\pm 15^\circ$ and rotated in any direction within 360° .
- By tightening the fixing hex socket head cap screw, securely retain the angle after adjustment.
- Can be mounted to round pipe.
- Application

Machine tool / Medical equipment / FPD production device / Semiconductor manufacturing device / Packing machine / Food machinery

Unit : mm

Part Number	D	L	L ₁	Tightening Torque *1 (N·m)	Fixing Hex Socket Head Cap Screw Tightening Torque Reference Value (N·m)	Screw With Ball Retention Torque *2 (N·m)	Max. Load Weight (kg)	Mass (g)
DFKWF-60-M6-PB-28	28	83	59	5.2	3	10	10	900
DFKWF-60-M6-PB-30	30	83	59	5.2	3	10	10	900
DFKWF-60-M6-PB-34	34	83	59	5.2	3	10	10	860
DFKWF-60-M6-PB-40	40	91	63	5.2	3	10	10	880
DFKWF-60-M6-PB-42.7	42.7	91	63	5.2	3	10	10	850

*1 : Screw tightening torque of the screw with ball.

*2 : Retention torque is the value indicated when the hex socket head cap screw is tightening to the torque indicated.

- Fixing rubber sheet is attached.

- Part number specification

DFKWF-60-M6-PB-30

