

- Stoppers for linear guides with threaded holes (fine) and knock pin mounting holes machined.
 - In combination with fine screw thread stopper bolts*1, fine adjustment of the screw-in depth is easy.
 - Knock pins enable easy main body positioning.
 - Supported rail sizes are 15 mm/20 mm/25 mm/30 mm/35 mm.
 - Hex socket head cap screws and knock pins for mounting are provided with all products.
- *1: Stopper bolts are not provided. The customer is asked to prepare them.

Application

- Table position adjustment
- Table retention and fall prevention
- Stoppers for emergencies

*: Check the A dimension based on the distance from the mounting surface to the top surface of the table and select accordingly.

Material/Finish



	NLSDN-N
Main Body	SS400 Ferrosferric Oxide Film (Black)
Hex Socket Head Cap Screw	SCM435 Ferrosferric Oxide Film (Black)
Knock Pin	SUS303

Usage Example

Example using **NLSCN-N**

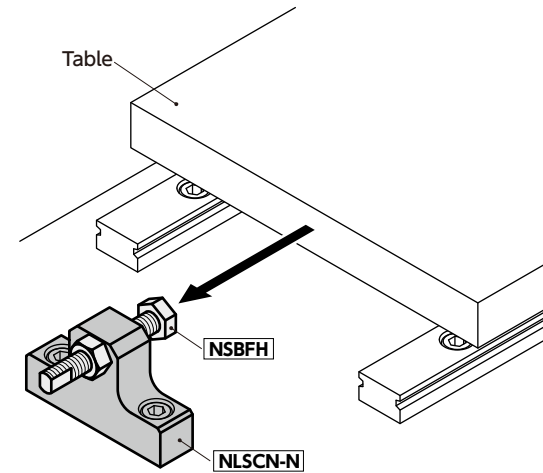

- Use the lock nut on the opposite side of the side that receives the force.



Unit : mm

Part Number	W	H	A	B	E	F	P	e	T	M (Fine)		D	d	Lc	Hex Socket Head Cap Screw	Knock Pin (Knock Pin Diameter Tolerance m6)	Mass (g)	
										Nominal of Thread	Pitch							
NLSDN-01-N	32	30	23.5	18	12	12	16	16	6	25	M6	0.75	5.5	4	6	M5×12	φ4×10	124.8
NLSDN-02-N	32	38	31.5	18	12	12	16	16	6	25	M6	0.75	5.5	4	6	M5×12	φ4×10	149.7
NLSDN-03-N	32	43	35.5	18	12	12	16	16	6	25	M6	0.75	5.5	4	6	M5×12	φ4×10	164.3
NLSDN-04-N	32	35	27.5	18	12	12	16	16	6	25	M8	1.0	5.5	4	6	M5×12	φ4×10	137.5
NLSDN-05-N	32	43	35.5	18	12	12	16	16	6	25	M8	1.0	5.5	4	6	M5×12	φ4×10	162.4
NLSDN-06-N	32	45	37.5	18	12	12	16	16	6	25	M8	1.0	5.5	4	6	M5×12	φ4×10	168.1
NLSDN-07-N	32	40	32.5	23	12	12	18	18	6	32	M8	1.0	6.6	4	6	M6×12	φ4×10	173.6
NLSDN-08-N	32	50	40.5	23	12	12	18	18	6	32	M8	1.0	6.6	4	6	M6×12	φ4×10	203
NLSDN-09-N	32	50	43.5	23	12	12	18	18	6	32	M8	1.0	6.6	4	6	M6×12	φ4×10	203.5
NLSDN-10-N	38	57	49.5	28	16	16	20	20	8	38	M8	1.0	9	5	8	M8×16	φ5×12	363.9
NLSDN-11-N	45	63	55.5	31	16	16	25	25	8	45	M8	1.0	9	5	8	M8×16	φ5×12	510.4

Related Products

Stopper bolts **NSBFH** are available.

Rounded head type stopper bolts **NSBRH** are available.

Stopper bolts with urethane pad **NSBUH** are available.



Part Number Specification

NLSDN-03-N



Cleanroom Wash & Packaging	Screw Combination	Screw Length Adjustment	Vibration Resistant	Laser Marking
Not Available	Not Available	Not Available	Not Available	Available / Add'l charge