

- Washers which prevent the cracking or scratching of acrylic panels, etc., due to screw tightening load when fixing panels with flat head machine screws.
- Available for Cross Recessed Flat Head Machine Screws in accordance with JIS B 1111, and Hexagon Socket Countersunk Head Screws in accordance with JIS B 1194.
- Supports panel thickness of 3 mm and 5 mm.
- Because the L dimension is longer than the panel thickness, tightening load is not applied to the panel when tightening the screws.
- Aluminum. When the material is to match the aluminum frame.

• Material/Finish



	<b>FPWA</b>
Main Body	A2017 Anodized (White)

Unit : mm

Part Number	Nominal	Compatible Panel Thickness	L	L <sub>1</sub>	T	D	D <sub>1</sub>	d	d <sub>1</sub>	Mass (g)
FPWA-4-3.5	4	3	3.5	6	2.5	7	14	4.1	9.3	1.1
FPWA-4-5.5	4	5	5.5	8	2.5	7	14	4.1	9.3	1.2
FPWA-5-3.5	5	3	3.5	6.5	3	8	15	5.1	11.5	1.1
FPWA-5-5.5	5	5	5.5	8.5	3	8	15	5.1	11.5	1.2
FPWA-6-3.5	6	3	3.5	7	3.5	9	16	6.1	13.8	1.5
FPWA-6-5.5	6	5	5.5	9	3.5	9	16	6.1	13.8	1.7

• Mounting

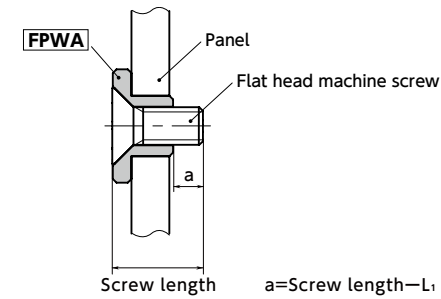

• Usage Example

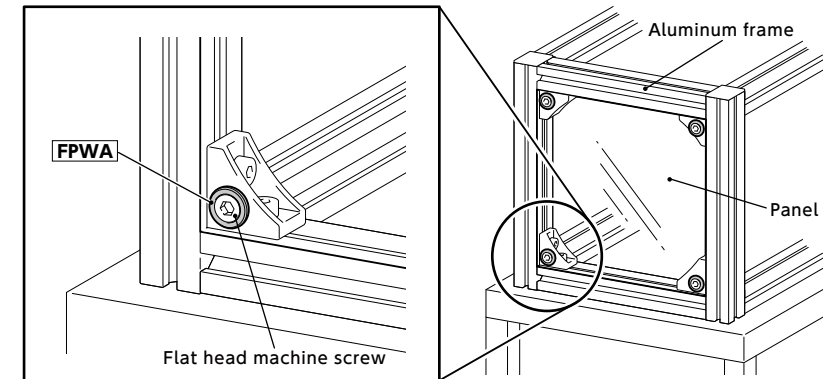

• Part Number Specification

**FPWA-4-3.5**



Cleanroom Wash & Packaging	Screw Length Adjustment	Vibration Resistant	Laser Marking
Please feel free to contact us	Not Available	Not Available	Not Available