

LBPS リニアクランプ・ズイー - 空気圧 - 常時閉 - ブレーキ機構つき - スリムタイプ 仕様変更

空気圧タイプ ブレーキ機構つき **N/C** 常時閉

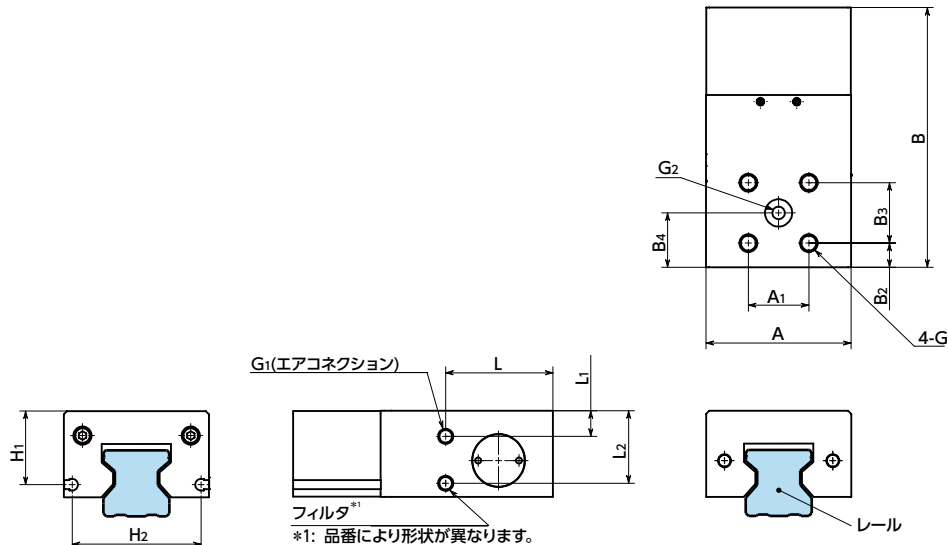

●クランプ部の形状は品番により異なります。各品番の形状は、CADデータをご確認ください。

寸法・性能

品番	保持力 (N)	寸法 (mm)										センサ溝		質量 (kg)		
		A	A ₁	B	B ₂	B ₃	G/深さ	G ₁	L	L ₁	L ₂	H ₁	H ₂			
LBPS-1501-AS2-A	400	34	15	76	8.5	15	M4/4.5	M3	31.5	4.5	17	16	M3	8.5	30.2	0.19
LBPS-1505-AS2-A	400	34	15	76	8.5	15	M4/4.5	M3	31.5	4.5	17	16	M3	8.5	30.2	0.19
LBPS-2001-AS2-A	600	44	20	81	7	20	M5/5.5	M3	33.5	4.5	20.5	17	M3	20.5	38.6	0.27
LBPS-2002-BS2-A	600	44	20	81	7	20	M5/5.5	M3	33.5	4.5	20.5	17	M3	20.5	38.6	0.27
LBPS-2005-AS2-A	600	44	20	81	7	20	M5/5.5	M3	33.5	4.5	20.5	17	M3	20.5	38.6	0.27
LBPS-2014-DS2-A	600	44	20	81	7	20	M5/5.5	M3	33.5	4.5	20.5	17	M3	20.5	38.6	0.27
LBPS-2501-AS2-A	750	48	20	86	8	20	M6/6.0	M5	35.5	8.5	24	18	M5	24.5	42.6	0.41
LBPS-2502-BS2-A	750	48	20	86	8	20	M6/6.0	M5	35.5	8.5	24	18	M5	24.5	42.6	0.42
LBPS-2502-DS2-A	750	48	20	86	8	20	M6/6.0	M5	35.5	8.5	24	18	M5	24.5	42.6	0.42
LBPS-2504-FS2-A	750	48	20	86	8	20	M6/6.0	M5	35.5	8.5	24	18	M5	24.5	42.6	0.42
LBPS-2505-AS2-A	750	48	20	86	8	20	M6/6.0	M5	35.5	8.5	24	18	M5	24.5	42.6	0.42
LBPS-2505-BS2-A	750	48	20	86	8	20	M6/6.0	M5	35.5	8.5	24	18	M5	24.5	42.6	0.42
LBPS-2514-DS2-A	750	48	20	86	8	20	M6/6.0	M5	35.5	8.5	24	18	M5	24.5	42.6	0.42
LBPS-3001-AS2-A	1200	60	22	109.5	8.5	22	M8/8.5	M5	41.5	6.5	30	19.5	M5	14.8	56.2	0.74
LBPS-3001-ES2-A	1200	60	22	109.5	8.5	22	M8/8.5	M5	41.5	6.5	30	19.5	M5	14.8	56.2	0.75
LBPS-3002-AS2-A	1200	60	22	109.5	8.5	22	M8/8.5	M5	41.5	6.5	30	19.5	M5	14.8	56.2	0.74
LBPS-3002-BS2-A	1200	60	22	109.5	8.5	22	M8/8.5	M5	41.5	6.5	30	19.5	M5	14.8	56.2	0.75
LBPS-3004-FS2-A	1200	60	22	109.5	8.5	22	M8/8.5	M5	41.5	6.5	30	19.5	M5	14.8	56.2	0.75
LBPS-3005-AS2-A	1200	60	22	109.5	8.5	22	M8/8.5	M5	41.5	6.5	30	19.5	M5	14.8	56.2	0.74
LBPS-3010-BS2-A	1200	60	22	109.5	8.5	22	M8/8.5	M5	41.5	6.5	30	19.5	M5	14.8	56.2	0.75
LBPS-3012-FS2-A	1200	60	22	109.5	8.5	22	M8/8.5	M5	41.5	6.5	30	19.5	M5	14.8	56.2	0.75
LBPS-3014-DS2-A	1200	60	22	109.5	8.5	22	M8/8.5	M5	41.5	6.5	30	19.5	M5	14.8	56.2	0.75
LBPS-3014-ES2-A	1200	60	22	109.5	8.5	22	M8/8.5	M5	41.5	6.5	30	19.5	M5	14.8	56.2	0.75
LBPS-3501-AS2-A	1900	70	24	124.5	7.5	24	M8/10.0	M5	41.5	7.5	35.5	19.5	M5	16.4	64.6	1.1
LBPS-3501-ES2-A	1900	70	24	124.5	7.5	24	M8/10.0	M5	41.5	7.5	35.5	19.5	M5	16.4	64.6	1.1

● 品番指定 ※価格・納期はNBKウェブサイトをご覧ください。

LBPS-2501-AS2-A



レバー位置変更 → P.xxxx

対応不可

品番	保持力 (N)	寸法 (mm)										センサ溝		質量 (kg)		
		A	A ₁	B	B ₂	B ₃	G/深さ	G ₁	L	L ₁	L ₂	H ₁	H ₂			
LBPS-3502-AS2-A	1900	70	24	124.5	7.5	24	M8/10.0	M5	41.5	7.5	35.5	19.5	M5	16.4	64.6	1.1
LBPS-3502-BS2-A	1900	70	24	124.5	7.5	24	M8/10.0	M5	41.5	7.5	35.5	19.5	M5	16.4	64.6	1.1
LBPS-3503-AS2-A	1900	70	24	124.5	7.5	24	M8/10.0	M5	41.5	7.5	35.5	19.5	M5	16.4	64.6	1.1
LBPS-3504-FS2-A	1900	70	24	124.5	7.5	24	M8/10.0	M5	41.5	7.5	35.5	19.5	M5	16.4	64.6	1.1
LBPS-3505-AS2-A	1900	70	24	124.5	7.5	24	M8/10.0	M5	41.5	7.5	35.5	19.5	M5	16.4	64.6	1.1
LBPS-3505-BS2-A	1900	70	24	124.5	7.5	24	M8/10.0	M5	41.5	7.5	35.5	19.5	M5	16.4	64.6	1.1
LBPS-3510-BS2-A	1900	70	24	124.5	7.5	24	M8/10.0	M5	41.5	7.5	35.5	19.5	M5	16.4	64.6	1.1
LBPS-3512-FS2-A	1900	70	24	124.5	7.5	24	M8/10.0	M5	41.5	7.5	35.5	19.5	M5	16.4	64.6	1.1
LBPS-3514-ES2-A	1900	70	24	124.5	7.5	24	M8/10.0	M5	41.5	7.5	35.5	19.5	M5	16.4	64.6	1.1
LBPS-4501-AS2-A	2600	86	26	132	11	26	M10/12.0	M5	46	9	45	24	M5	20	80.6	1.7
LBPS-4501-ES2-A	2600	86	26	132	11	26	M10/12.0	M5	46	9	45	24	M5	20	80.6	1.8
LBPS-4502-AS2-A	2600	86	26	132	11	26	M10/12.0	M5	46	9	45	24	M5	20	80.6	1.7
LBPS-4502-BS2-A	2600	86	26	132	11	26	M10/12.0	M5	46	9	45	24	M5	20	80.6	1.7
LBPS-4503-AS2-A	2600	86	26	132	11	26	M10/12.0	M5	46	9	45	24	M5	20	80.6	1.8
LBPS-4504-FS2-A	2600	86	26	132	11	26	M10/12.0	M5	46	9	45	24	M5	20	80.6	1.7
LBPS-4505-AS2-A	2600	86	26	132	11	26	M10/12.0	M5	46	9	45	24	M5	20	80.6	1.7
LBPS-4505-BS2-A	2600	86	26	132	11	26	M10/12.0	M5	46	9	45	24	M5	20	80.6	1.8
LBPS-4510-BS2-A	2600	86	26	132	11	26	M10/12.0	M5	46	9	45	24	M5	20	80.6	1.8
LBPS-4512-FS2-A	2600	86	26	132	11	26	M10/12.0	M5	46	9	45	24	M5	20	80.6	1.7
LBPS-4514-DS2-A	2600	86	26	132	11	26	M10/12.0	M5	46	9	45	24	M5	20	80.6	1.8
LBPS-4514-ES2-A	2600	86	26	132	11	26	M10/12.0	M5	46	9	45	24	M5	20	80.6	1.7
LBPS-5501-AS2-A	3600	100	30	132	9	30	M10/14.0	M5	46	10	51	24	M5	20	94.6	2.2
LBPS-5501-ES2-A	3600	100	30	132	9	30	M10/14.0	M5	46	10	51	24	M5	20	94.6	2.3
LBPS-5502-AS2-A	3600	100	30	132	9	30	M10/14.0	M5	46	10	51	24	M5	20	94.6	2.3
LBPS-5502-BS2-A	3600	100	30	132	9	30	M10/14.0	M5	46	10	51	24	M5	20	94.6	2.3
LBPS-5503-AS2-A	3600	100	30	132	9	30	M10/14.0	M5	46	10	51	24	M5	20	94.6	2.4
LBPS-5505-AS2-A	3600	100	30	132	9	30	M10/14.0	M5	46	10	51	24	M5	20	94.6	2.3
LBPS-5505-BS2-A	3600	100	30	132	9	30	M10/14.0	M5	46	10	51	24	M5	20	94.6	2.3
LBPS-5510-BS2-A	3600	100	30	132	9	30	M10/14.0	M5	46	10	51	24	M5	20	94.6	2.4
LBPS-5512-FS2-A	3600	100	30	132	9	30	M10/14.0	M5	46	10	51	24	M5	20	94.6	2.3
LBPS-5514-ES2-A	3600	100	30	132	9	30	M10/14.0	M5	46	10	51	24	M5	20	94.6	2.3